

ROOTS

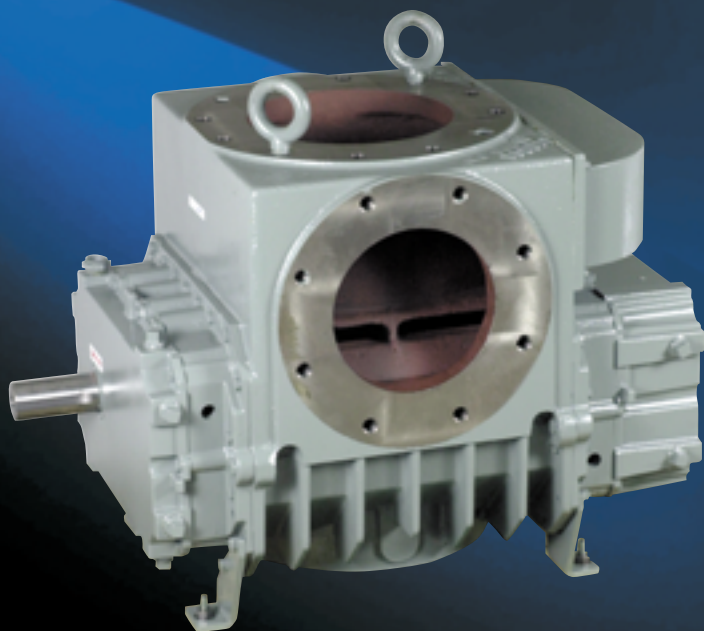

Rotary Positive Blowers & Exhausters

B-05X93
April 2002



ABOUT ROOTS

Dresser ROOTS, Dresser, Inc. is the longest continuously run manufacturer of rotary positive displacement blowers in the United States. In 1854, Francis and Philander Roots, woolen mill owners in Connersville, IN, stumbled upon the principles that drive the rotary positive displacement concept.



Francis and Philander's, attempts to improve efficiency in their mill's power system failed as the wooden lobed water wheel warped and jammed when put to use. In the course of investigating the problem on dry land, one of the brothers turned a shaft and rotated the pair of impellers. The impellers produced a large wind force blowing off his brother's hat. At that point, the brothers decided that they had a better blower than water wheel. Thus, the ROOTS blower concept and the ROOTS Blower Company was created in their hometown of Connersville, Indiana, USA.

The rotary positive blower, invented around the same time as the telegraph, and steam engine, has withstood the test of time as the other inventions have fallen along the wayside. During the early years, the units proved reliable as low-pressure air sources for anything from blacksmith forges, to mine ventilation, to the first New York City subway.



In 1893, an engineer broke from the ROOTS Blower Company and started the Connersville Blower Company. These two competitors continued in Connersville until 1931. At that time, the International Derrick and Equipment Company (IDECO) purchased both firms and created the ROOTS-Connersville Blower Company.

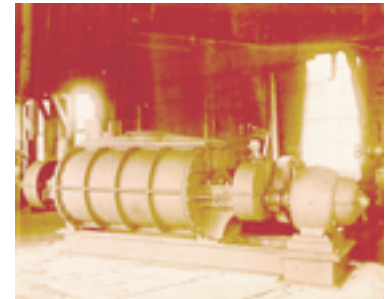

During 1931, ROOTS began to produce centrifugal compressors. Today, ROOTS manufactures integral-gear, and pedestal mounted, overhung, single-stage centrifugal compressors as well as horizontally split multi-stage centrifugal compressors.

During WWII ROOTS supplied, Navy submarines and large surface craft with a special screw compressor used for ballast blowing.

In 1944, Dresser Industries, Inc. acquired ROOTS to expand its range of services for the gas and oil industries. During 1998, Dresser Industries merged with the Halliburton company. In 1999 the ROOTS and DMD Division of Dresser Equipment Group, Inc combined and in 2000 joined with the Instrument Division to form Dresser Measurement. During 2001, Dresser Equipment Group separated from Halliburton through a management buy-out to form Dresser, Inc.

Accessories

Available accessories for ROOTS blowers, gas blowers and exhausters include driver, relief valves, inlet and discharge silencers, inlet filters, check valves, extended base, V-belt drive or flexible coupling and drive guards.

Contact your Authorized ROOTS Distributor or Factory Sales Representative for details concerning your specific application or installation.

Warranty

The Dresser ROOTS warranty covers URAI & URAI-J 2 1/2 to 7 inch gear diameter and RAM & RAM-J 4 1/2 to 6 inch gear diameter units for a full 24 months from original start up date or 30 months from shipment, whichever occurs first. Full details are supplied in Warranty Policy WP-5020.

OPERATING PRINCIPLES:



ROOTS™ rotary positive displacement principle

The basic unit consists of two figure eight shaped impellers mounted on parallel shafts. The impellers rotate in opposite directions within a cylindrical casing. As each impeller passes the inlet, it traps a definite volume of air/gas and carries it around the casing to the discharge where the gas is expelled. The cycle repeats four times with every revolution.

All ROOTS™ rotary positive blowers have close tolerances between the impellers and casing to minimize back-slippage of gas and to improve efficiency.

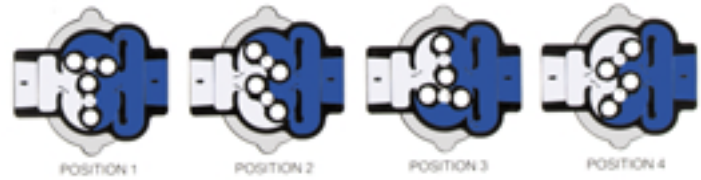

ROOTS WHISPAIR principle

Lower Air Pulsation

Exclusive ROOTS™ WHISPAIR™ blowers operate using up to 50% less pressure pulsation than conventional blowers due to the pressure equalizing effect of the WHISPAIR jet design.

Lower Vibration, Lower Noise

Pressure pulses, inherent in rotary-lobe design, are the major source of blower noise. The rapid backflow of air into the blower casing from pressurized air/gases in the discharge line, four times per revolution in a bi-lobe rotary blower, result in high noise levels. By pre-pressurizing the low pressure pocket as it is moved through the blower casing, the WHISPAIR cavity reduces the magnitude of discharge pulsations versus conventional blowers. The WHISPAIR design controls the backflow air into the blower, reducing noise by approximately 5 dB vacuum, 3 dB pressure.

Longer Bearing Life

These smoothed pulsations cause less shock being transmitted through the impellers to the bearings, resulting in approximately 20% longer bearing life.

Contents

Accessories.....	2
Warranty.....	2
OPERATING PRINCIPLES:.....	3
Universal RAI® series	4
U-RAI Performance Tables.....	5
ROOTS XLP WHISPAIR.....	7
XLP series Performance Table.....	7
RAM™ series.....	8
RAM Performance Tables.....	9
RCS series.....	10
RCS series Performance Table.....	11

WHISPAIR DRY EXHAUSTERS.....	12
RAM WHISPAIR DRY HIGH PRESSURE BLOWERS.....	13
DVJ & DPJ Performance Table.....	13
Configurations.....	14
Dimensional Drawings & Tables.....	14
Typical Application Packages.....	18
Other ROOTS products.....	20
Authorized ROOTS Distributor.....	20

Universal RAI® series

rotary positive blowers/vacuum exhausters

Basic Equipment Description

All Universal RAI (U-RAI) series blowers are heavy duty rotary blowers in a compact, sturdy design engineered for continuous and maximum reliability. These blowers have grease lube on the drive-end with splash oil lube on gear end. ROOTS exclusive “figure 8” gearbox design improves oil distribution and lengthens bearing and gear life.

This series features a grey iron casing, carburized and ground alloy steel spur timing gears secured to steel shafts with a taper fit and locknut, and grey iron involute impellers. Oversized anti-friction bearings are used, with a heavy duty cylindrical roller bearing at the drive shaft to withstand V-belt pull.

Standard Universal RAI air units

Frames 22 thru 718



The standard U-RAI® blower features universal detachable rugged steel mounting feet to permit easy in-field adaptation to either vertical or horizontal installation requirements and any of four drive shaft positions— top, bottom, right or left hand. All frame sizes are center-timed to allow for rotation in either direction.

Universal RAI-J WHISPAIR™ air units

Frames 33J thru 56J



ROOTS refined the standard U-RAI line using computer aided design techniques to incorporate the ROOTS exclusive WHISPAIR™ jet. The WHISPAIR jet uses shock suppression techniques for noise and pulsation reduction. This exclusive WHISPAIR feature can reduce noise 3-5 dB on typical installations. Like the standard U-RAI blower, the U-RAI-J features universal detachable rugged steel mounting feet to permit easy in-field adaptation.

Universal RAI gas units

Frames 32GJ thru 615GJ



U-RAI gas blowers feature mechanical seals and Viton o-rings. The seal system is designed to meet or exceed gas industry safety standards, including provisions for purge gas in the headplates. The U-RAI gas blower uses detachable rugged steel mounting feet for easy in-field adaptation of drive shaft position. Conversion to meet vertical or horizontal installation requirements is achieved by exchanging the orientation configured mounting feet.

U-RAI Performance Tables

Frame Size	Speed RPM	1 PSI		2 PSI		3 PSI		4 PSI		5 PSI		6 PSI		7 PSI		10 PSI		11 PSI		12 PSI		13 PSI		14 PSI		15 PSI		MAX. VACUUM		
		CFM	BHP	CFM	BHP	CFM	BHP	CFM	BHP	CFM	BHP	CFM	BHP	CFM	BHP	CFM	BHP	CFM	BHP	CFM	BHP	CFM	BHP	CFM	BHP	CFM	BHP	*Hg	CFM	BHP
22	1160	10	0.2	7	0.3	4	0.3	2	0.4																			4	6	0.3
	3600	49	0.6	46	0.8	43	1.1	41	1.3	39	1.6	38	1.8	36	2.1	32	2.8	31	3.1	29	3.3							14	28	2.0
	5275	76	0.8	73	1.2	70	1.6	68	1.9	66	2.3	64	2.7	63	3.1	59	4.2	57	4.5	56	4.9							15	53	3.1
24	1160	24	0.3	19	0.4	15	0.6	11	0.8	8	0.9																6	12	0.6	
	3600	102	0.8	97	1.3	93	1.8	89	2.3	86	2.8	83	3.3	81	3.8												14	69	3.8	
	5275	156	1.2	150	1.9	146	2.7	143	3.4	140	4.2	137	4.9	135	5.6												15	119	5.8	
32	1160	40	0.4	34	0.6	30	0.9	27	1.1	24	1.3	21	1.6	19	1.8												10	18	1.3	
	2800	113	1.0	108	1.6	104	2.1	101	2.7	98	3.2	95	3.8	93	4.3	86	6.0	84	6.5	82	7.1	81	7.6	79	8.2	77	8.7	15	78	4.5
	3600	149	1.3	144	2.0	140	2.7	137	3.4	134	4.1	131	4.8	129	5.5	122	7.7	120	8.4	118	9.1	117	9.8	115	10.5	113	11.2	16	110	5.9
33	1160	55	0.5	48	0.8	43	1.1	39	1.4	35	1.7	31	2.1	28	2.4												10	27	1.7	
	2800	156	1.2	149	2.0	144	2.7	140	3.5	136	4.2	132	5.0	129	5.7	120	8.0	118	8.7	116	9.5						14	113	5.6	
	3600	205	1.6	199	2.5	193	3.5	189	4.5	185	5.4	181	6.4	178	7.4	170	10.3	167	11.2	165	12.2						15	159	7.6	
36	1160	95	0.7	85	1.2	78	1.7	72	2.3	66	2.8	61	3.3	57	3.8												10	55	2.7	
	2800	262	2.0	253	3.3	245	4.5	239	5.8	234	7.0	229	8.3	224	9.5												12	213	7.9	
	3600	344	2.9	334	4.5	327	6.1	321	7.7	315	9.3	310	10.9	306	12.5												15	278	12.7	
42	860	38	0.4	32	0.6	28	0.9	24	1.1	21	1.3	18	1.5	15	1.8												8	19	1.1	
	1760	92	0.8	87	1.3	82	1.8	78	2.2	75	2.7	72	3.1	69	3.6	62	5.0	60	5.5	58	5.9						14	56	3.5	
	3600	204	1.7	198	2.6	194	3.6	190	4.5	186	5.5	183	6.4	181	7.4	173	10.2	171	11.2	169	12.1	167	13.1	165	14.1	163	15.0	15	160	8.0
45	860	79	0.6	68	1.1	60	1.5	53	2.0	48	2.4	42	2.9	37	3.4												8	46	1.9	
	1760	188	1.3	177	2.2	169	3.1	162	4.1	156	5.0	151	5.9	146	6.9	133	9.6										12	134	5.8	
	3600	410	3.4	400	5.3	392	7.2	385	9.1	379	11.0	374	12.9	369	14.8	356	20.5										15	332	15.9	
47	860	105	0.8	92	1.4	82	2.0	73	2.6	66	3.2	59	3.8	53	4.4												8	63	2.5	
	1760	249	1.6	236	2.8	225	4.0	217	5.3	209	6.5	203	7.7	196	8.9												12	181	7.5	
	3600	542	4.5	529	7.0	519	9.5	510	12.0	503	14.3	496	17.0	490	19.5												15	452	19.8	
53	700	72	0.6	63	1.0	56	1.4	51	1.8	46	2.2	42	2.6	38	3.0												10	36	2.2	
	1760	211	1.7	203	2.7	196	3.7	191	4.7	186	5.7	181	6.7	177	7.7	167	10.8	163	11.8	160	12.8	157	14.2	155	15.2	14	158	7.5		
	2850	355	3.3	346	5.0	340	6.6	334	8.2	329	9.9	325	11.5	321	13.2	310	18.1	307	19.7	304	21.3	301	23.0	298	24.6	295	26.2	16	391	14.0
56	700	123	0.9	110	1.6	100	2.2	92	2.9	85	3.6	78	4.3	72	4.9												10	70	3.5	
	1760	358	2.6	345	4.6	335	6.0	326	7.7	319	9.4	312	11.1	306	12.8	290	17.9	285	19.6	280	276	23.0					14	276	12.3	
	2850	598	5.2	585	8.0	575	10.7	567	13.5	560	16.2	553	19.0	547	21.7	531	30.0	526	32.7	521	517	38.2					16	501	23.2	
59	700	187	1.2	170	2.2	158	3.2	147	4.2	138	5.1	130	6.1														8	135	4.1	
	1760	529	3.9	513	6.4	500	8.9	490	11.4	480	13.8	472	16.3	464	18.8												12	445	15.6	
	2850	881	7.8	865	11.8	852	15.8	842	19.9	832	23.9	824	27.9	816	31.9												15	770	32.1	
65	700	140	1.0	126	1.8	116	2.6	107	3.3	100	4.1	93	4.8	86	5.5	70	7.8										12	71	4.7	
	1760	400	3.4	387	5.3	377	7.2	368	9.1	360	11.0	353	12.8	347	14.7	330	20.4	325	22.3	320	24.2	316	26.1	311	27.9	307	29.8	16	300	15.8
	2350	546	5.2	523	7.7	522	10.3	513	12.8	506	15.3	499	17.8	492	20.3	475	27.4	470	30.4	466	32.9	461	35.5	457	38.0	452	40.5	16	445	21.6
68	700	224	1.5	203	2.7	187	3.9	172	5.1	160	6.3	149	7.5	139	8.7												10	135	6.2	
	1760	643	4.9	621	7.9	605	10.9	591	14.0	579	17.0	567	20.0	557	23.1	530	32.2	522	35.2	515	38.2	507	41.3	500	44.3		15	495	23.5	
	2350	876	7.3	855	11.4	838	15.4	824	19.5	812	23.5	801	27.6	790	31.6	763	43.8	755	47.8	748	51.9	740	55.9	733	60.0		16	715	34.0	
615	700	420	2.6	380	4.8	351	7.1	323	9.3	301	11.6	279	13.8	260	16.2												8	292	9.1	
	1760	1205	8.1	1164	13.9	1133	19.5	1107	25.2	1084	30.8	1063	36.5	1044	42.2												12	997	35.0	
	2350	1641	11.9	1601	19.3	1570	27.0	1544	34.6	1521	43.2	1500	49.8	1481	57.4												14	1389	54.9	
76	575	195	1.3	179	2.3	168	3.3	158	4.3	150	5.4	142	6.4	134	7.4	115	10.4										12	117	6.2	
	1400	526	4.0	511	6.4	500	9.0	490	11.5	481	13.9	473	16.4	466	18.8	447	26.3	441	28.7	436	31.2	421	33.7	415	36.1	421	38.6	16	413	20.4
	2050	788	6.9	772	10.5	761	14.2	751	17.8	742	21.4	734	25.0	727	28.6	708	39.5	703	43.1	697	46.7	684	50.4	679	54.0	682	57.6	16	674	30.6
711	575	362	2.2	336	4.0	316	5.9	299	7.7	284	9.6	271	11.4	258	13.3	226	18.8										12	228	11.2	
	1400	970	6.5	944	11.0	925	15.5	908	20.0	893	24.5	880	29.0	867	33.5	835	47.1										15	793	34.4	
	2050	1450	10.9	1424	17.5	1404	24.1	1387	30.7	1373	37.3	1359	43.9	1347	50.5	1315	70.3										16	1256	54.6	
718	575	600	3.3	563	6.3	534	9.3	510	12.3	489	15.4	470	18.4																	

U-RAI-J Performance Tables

Frame Size	Speed RPM	4" Hg Vacuum		6" Hg Vacuum		8" Hg Vacuum		10" Hg Vacuum		12" Hg Vacuum		14" Hg Vacuum		15" Hg Vacuum		16" Hg Vacuum		MAX. PRESSURE		
		CFM	BHP	CFM	BHP	CFM	BHP	CFM	BHP	CFM	BHP	CFM	BHP	CFM	BHP	CFM	BHP	PSI	CFM	BHP
33J	1160	47	0.8	40	1.1	33	1.4	27	1.7									7	28	2.4
	2800	148	2.0	141	2.7	134	3.4	128	4.1	121	4.9	113	5.6					12	116	9.5
	3600	197	2.7	190	3.6	184	4.6	177	5.3	170	6.3	163	7.2	159	7.6			12	165	12.4
36J	1160	83	1.2	74	1.7	65	2.2	55	2.7									7	57	3.8
	2800	251	3.2	241	4.4	232	5.7	223	6.6	213	7.9	202	9.1					7	224	9.5
	3600	332	4.4	323	6.0	313	7.6	304	8.7	294	10.3	284	11.9	278	12.7			7	306	12.5
45J	860	66	1.1	56	1.5	46	1.9											7	37	3.4
	1760	175	2.2	164	3.1	154	4.0	144	4.9	134	5.8							10	133	9.5
	3600	398	5.2	387	7.1	377	8.9	367	10.3	356	12.2	345	14.1	339	15.0	332	15.9	10	356	20.5
47J	860	89	1.3	76	1.9	63	2.5	51	3.0									7	53	4.4
	1760	233	2.9	220	4.1	207	5.3	194	6.3	181	7.5							7	196	9.0
	3600	526	6.9	513	9.3	500	11.8	488	13.6	474	16.1	460	18.5	452	19.8			7	490	19.5
56J	700	108	1.5	95	2.2	82	2.9	70	3.5									7	72	4.9
	1760	342	4.3	329	5.9	316	7.6	304	9.0	291	10.6	276	12.3					10	290	17.9
	2850	583	7.9	570	10.6	557	13.2	545	15.2	532	17.9	517	20.6	510	21.9	502	23.2	13	517	38.0

URAI- J Notes:

1. Pressure ratings based on inlet air at standard pressure of 14.7 psia, standard temperature of 68° F, and specific gravity of 1.0.
2. Vacuum ratings based on inlet air at standard temperature of 68° F, discharge of 30" Hg and Specific gravity of 1.0.

URAI-G Notes:

1. Performance based on METHANE at standard pressure of 14.7 psia, standard temperature of 68° F, and specific gravity of 0.55.
2. For vacuum service consult Factory or nearest ROOTS sales office.

U-RAI-G Performance Tables

FRAME	Speed RPM	1 PSI		2 PSI		3 PSI		4 PSI		5 PSI		6 PSI		7 PSI		8 PSI		10 PSI		11 PSI		12 PSI		13 PSI		14 PSI		15 PSI		MAX. VACUUM						
		CFM	BHP	CFM	BHP	CFM	BHP	CFM	BHP	CFM	BHP	CFM	BHP	CFM	BHP	CFM	BHP	CFM	BHP	CFM	BHP	CFM	BHP	CFM	BHP	CFM	BHP	CFM	BHP	CFM	BHP	CFM	BHP			
32	1200	37	0.3	30	0.5	24	0.8	20	1.0	16	1.2	12	1.5																			8	15	1.0		
	1800	64	0.5	57	0.9	51	1.2	47	1.6	43	1.9	39	2.3	36	2.6	33	3.0	27	3.7													10	35	1.8		
	2500	95	0.8	88	1.3	83	1.8	78	2.3	74	2.7	71	3.2	67	3.7	64	4.2	59	5.2	56	5.7	54	6.2	51	6.7	49	7.2					13	56	3.3		
	3600	145	1.3	138	2.0	133	2.7	128	3.4	124	4.1	120	4.8	117	5.5	114	6.3	108	7.7	106	8.4	103	9.1	101	9.8	98	10.5	96	11.2			16	93	5.9		
33	1200	52	0.4	42	0.7	36	1.1	29.6	1.4	24	1.7	20	2.0																			8	23	1.3		
	1800	89	0.7	80	1.2	72	1.7	66.5	2.1	61	2.6	57	3.1	52	3.6	48	4.1	40	5.0														10	51	2.5	
	2500	132	1.1	123	1.7	116	2.4	110	3.1	104	3.7	100	4.4	95	5.1	91	5.8	84	7.1	80.4	7.8	77	8.4										13	80	4.5	
	3600	200	1.8	190	2.7	183	3.7	177	4.7	172	5.6	167	6.6	163	7.6	159	8.5	152	10.5	148	11.4	145	12.4										15	137	7.7	
36	1200	91	0.7	78	1.2	68	1.7	60	2.3	52	2.8	46	3.3	39	3.9																		8	50	2.2	
	1800	152	1.1	139	1.9	129	2.7	121	3.5	113	4.3	107	5.1	101	5.9																		10	99	4.1	
	2500	224	1.7	211	2.9	201	4.0	192	5.1	185	6.2	178	7.3	172	8.4																			13	150	7.5
	3600	336	2.9	323	4.5	313	6.1	304	7.7	297	9.3	290	10.9	284	12.5																			15	248	12.7
42	1200	54	0.4	46	0.7	40	1.0	35	1.4	30	1.7	26	2.0	22	2.3	19	2.6																8	10	1.3	
	1800	90	0.7	82	1.1	76	1.6	71	2.1	66	2.6	62	3.0	59	3.5	55	4.0	49	4.9	46	5.4	43	5.9										10	58	2.5	
	2500	132	1.0	124	1.7	118	2.4	113	3.0	109	3.7	105	4.3	101	5.0	98	5.7	91	7.0	88	7.6	85	8.3	83	9.0	80	9.6	77	10.3			13	88	4.5		
	3600	199	1.7	191	2.7	185	3.6	180	4.6	175	5.5	171	6.5	168	7.4	164	8.4	158	10.3	155	11.2	152	12.2	149	13.1	147	14.1	144	15.0			16	140	8.0		
45	1200	111	0.8	97	1.4	86	2.1	77	2.7	69	3.3	61	4.0	55	4.6	49	5.2																8	67	2.6	
	1800	184	1.3	170	2.3	159	3.2	150	4.2	142	5.1	134	6.1	128	7.0	121	8.0	110	9.9															10	126	4.9
	2500	268	2.0	254	3.4	243	4.7	234	6.0	226	7.3	219	8.6	212	10.0	206	11.3	195	13.9															13	189	8.9
	3600	402	3.4	387	5.3	377	7.2	367	9.1	359	11.0	352	12.9	345	14.8	339	16.7	328	20.5															16	297	15.9
47	1200	148	1.1	131	1.9	117	2.7	105	3.6	95	4.4	86	5.2	78	6.1																			8	92	3.5
	1800	244	1.8	226	3.0	213	4.3	201	5.5	191	6.8	182	8.0	173	9.3																			10	171	6.5
	2500	356	2.7	338	4.4	324	6.2	313	7.9	303	9.7	293	11.4	285	13.1																			13	255	11.7
	3600	531	4.5	513	7.0	500	9.5	488	12.0	478	14.5	469	17.0	460	19.5																			15	410	19.8
53	800	77	0.6	66	1.1	57	1.5	49	2.0	43	2.4	37	2.9	32	3.4																			8	41	1.9
	1400	157	1.2	145	2.0	136	2.8	129	3.6	122	4.4	116	5.2	111	6.0	106	6.8	96	8.5	92	9.3	88	10.1											10	109	4.2
	1800	209	1.7	198	2.7	189	3.8	181	4.8	175	5.8	169	6.9	163	7.9	158	9.0	149	11	145	12.1	141	13.1	137	14.1	133	15.2						13	144	7.1	
	2850	348	3.3	336	5.0	327	6.6	320	8.3	313	9.9	307	11.5	302	13.2	297	14.8	287	18.1	283	19.7	279	21.4	275	23	271	24.6	268	26.3			16	262	14.0		
56	800	134	1.0	117	1.7	104	2.5	92	3.3	82	4.1	73	4.8	64	5.6	57	6.4																	8	79	3.2
	1400	267	2.0	250	3.3	236	4.7	225	6.0	215	7.3	206	8.7	197	10.0	190	11.4	176	14.1	169	15.4	163	16.8	157	18.1									10	195	7.0
	1800	355	2.7	338	4.5	325	6.2	313	7.9	303	9.7	294	11.4	286	13.1	278	14.9	264	18.3	257	20.1	251	21.8	245	23.5									13	257	11.7
	285																																			

ROOTS XLP WHISPAIR

Extra Low Pulse TRI-Lobe Blowers

Basic Blower Description

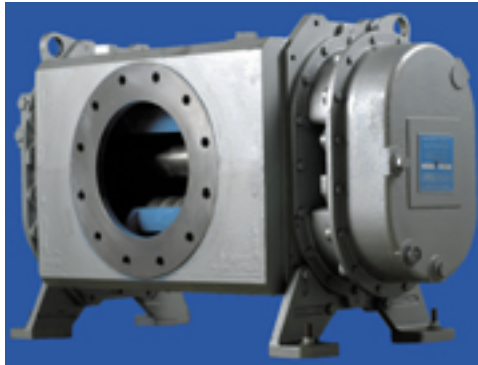

ROOTS™ XLP WHISPAIR™ blowers are specially designed to reduce noise and power loss by combining the exclusive ROOTS™ WHISPAIR™ wraparound plenum and exclusive double jet to control pressure equalization with a tri-lobe impeller design. The Tri-lobe impeller profile ensures maximum volumetric efficiency and minimum absorbed power without sacrificing torsional rigidity.

Designed for long operating life, the XLP tri-lobe blower features large-diameter rolling element bearings with high load carrying capacity. XLP blowers are splash lubricated on both ends incorporating an oil slinger design that eliminates the need for lip seals.

Taper mounted, precision ground and hardened high-grade alloy steel gears ensure smooth, quiet operation. Cylinder and headplates are made from cast iron with dynamically balanced ductile iron impellers and integral shafts.

All units are designed with rugged steel mounting feet that permit in-field adaptability to either vertical or horizontal installation requirements.

XLP series Performance Table

Frame Size	Speed RPM	2 PSI		6 PSI		10 PSI		12 PSI		15PSI		MAX. VACUUM		
		CFM	BHP	CFM	BHP	CFM	BHP	CFM	BHP	CFM	BHP	*Hg	CFM	BHP
110	1750	576	6.2	511	17.8	467	29.4	448	35.2			8.0	520	11.7
	2950	1032	11.9	967	31.4	923	51.0	904	60.8	878	75.4	12.0	925	30.1
	3650	1298	16.1	1233	40.3	1189	64.5	1170	76.6	1144	94.7	15.0	1146	46.5
108	1750	769	8.3	682	23.8	623	39.2	597	47.0			8.0	694	15.6
	2950	1377	15.7	1291	41.8	1231	67.9	1206	80.9			12.0	1234	40.0
	3650	1732	21.1	1646	53.4	1586	85.7	1561	101.8			15.0	1529	61.9
210	1750	1243	13.9	1131	38.2	1055	62.5	1022	74.7	978	93.0	8.0	1146	25.2
	2300	1681	19.9	1570	51.9	1493	83.9	1460	99.8	1416	123.8	12.0	1496	49.5
	2850	2119	27.3	2008	66.9	1931	106.5	1899	126.3	1855	156.1	15.0	1859	76.7
208	1750	1656	18.4	1507	50.8	1405	83.2	1362	99.4			8.0	1527	33.4
	2300	2240	26.2	2091	68.8	1989	111.4	1946	132.7			12.0	1993	65.7
	2850	2824	35.7	2676	88.5	2573	141.3	2530	167.7			15.0	2476	101.9

- Notes:
1. Pressure ratings based on inlet air at standard pressure of 14.7 psia, standard temperature of 68° F, and specific gravity of 1.0.
 2. Vacuum ratings based on inlet air at standard temperature of 68° F, discharge of 30" Hg and Specific gravity of 1.0.

RAM™ series

rotary positive blowers/exhausters

Basic Equipment Description

ROOTS RAM™ series units are recognized as the most volumetrically efficient equipment in the industry.

Unless otherwise noted, RAM series equipment may operate under either vacuum or pressure application with no equipment modification, and can provide simultaneous vacuum and pressure for a system with a single unit.

RAM series units feature integral-shaft ductile iron impellers with involute profiles.



Headplates and the rigid casing are cast grey iron, while the drive end and gear covers are aluminum. Carburized ground alloy steel spur timing gears are securely mounted on taper end shafts. All units in the RAM series feature cylindrical roller bearings for maximum life.

Detachable steel mounting feet to permit in-field adaptability to either vertical or horizontal installation requirements.

Piston ring shaft seals reduce gas leakage through the headplates, while lip-type oil seals prevent lubricant from entering the air chamber. RAM units are splash lubricated on both sides with high volume oil reservoirs.

Standard RAM rotary air units

Frames 404 thru 624

All standard units are center-timed to allow rotation in either direction.



RAM WHISPAIR rotary air units

Frames 404J thru 624J

RAM-J units feature the exclusive WHISPAIR jets to control pressure equalization by feeding backflow in the direction of impeller movement, thereby aiding rotation.

RAM WHISPAIR water sealed exhausters

Frames 404J thru 624J

RAM WHISPAIR units are available equipped with an inlet spray nozzle and seal water flow meter for water injection. This feature cools the vacuum unit to enable the unit to reach deeper vacuum while minimizing potential impeller and casing distortion.

RAM gas units

Available on all RAM Frame sizes

RAM standard gas blowers feature a piston ring system between the compression chamber and vent cavities. All vent cavities are plugged for purge or drain. Special long-life mechanical seals and viton O-rings are installed at each bearing to control gas and oil leakage. The seal incorporates a unique geometry that promotes enhanced cooling and extended seal life.

RAM gas units are suitable for both vacuum or pressure service. Alternate material units and optional O-ring material are available for gas units, please contact the factory for more information.

RAM Performance Tables

Frame Size	Speed RPM	4 PSI		6 PSI		8 PSI		10 PSI		12 PSI		15 PSI		18PSI		MAX. VACUUM		
		CFM	BHP	CFM	BHP	CFM	BHP	CFM	BHP	CFM	BHP	CFM	BHP	CFM	BHP	*Hg	CFM	BHP
404	1750	149	3.6	139	5.3	130	7.0	123	8.7	116	10.4					14.0	115	5.9
	2950	281	7.0	271	9.8	262	12.6	255	15.4	248	18.2	239	22.4			15.0	240	11.2
	4000	396	8.3	386	14.2	378	17.9	370	21.6	364	25.3	355	30.9	347	37.0	16.0	353	15.9
406	1750	225	5.4	210	8.0	198	10.5	187	13.0	177	15.6					14.0	173	9.0
	2950	426	10.5	411	14.7	398	18.9	387	23.1	377	27.3	363	33.6			15.0	365	16.9
	4000	601	15.0	586	20.1	574	26.0	562	31.9	552	37.0	539	46.5	526	54.0	16.0	531	23.6
409	1750	338	8.5	315	12.0	296	15.8	279	20.0	264	23.5					14.0	259	13.5
	2950	638	15.2	615	21.5	596	27.8	579	34.1	564	40.4	544	49.8			15.0	546	24.4
	4000	900	24.0	878	30.0	859	38.1	842	46.8	827	55.0	806	67.9	788	79.0	16.0	795	35.1
412	1750	450	11.0	420	16.0	394	21.0	372	26.0	352	32.0					14.0	343	17.7
	2950	849	19.9	819	28.3	794	36.6	772	45.0	752	53.4	724	66.0			15.0	728	32.3
	4000	1199	28.8	1169	39.9	1144	51.0	1121	62.2	1101	73.3	1074	90.0			16.0	1059	46.5
418	1750	675	16.5	630	24.0	592	31.7	559	39.0							14.0	515	26.5
	2950	1275	29.5	1230	42.1	1192	54.7	1159	67.3							15.0	1092	48.4
	4000	1800	42.9	1755	59.7	1717	73.4	1684	93.1							16.0	1590	69.7
616	1170	718	16.9	672	24.9	633	32.9	599	40.9	568	49.0					13.0	579	25.9
	1750	1176	26.2	1130	38.2	1091	50.1	1056	62.0	1025	73.9					14.0	1013	42.0
	3000	2162	48.9	2116	68.7	2077	88.5	2043	108.3	2012	128.0	1970	157.7			16.0	1946	81.7
624	1170	1077	25.4	1008	37.5	950	49.5	899	61.5							13.0	869	39.0
	1750	1764	39.9	1695	57.8	1637	75.7	1585	93.6							14.0	1519	63.4
	3000	3244	77.6	3175	107.3	3117	137.0	3065	166.7							16.0	2920	124.6

RAM-J and RAM-GJ Performance Tables

Frame Size	Speed RPM	4 PSI		6 PSI		8 PSI		10 PSI		12 PSI		15 PSI		18PSI		MAX. VACUUM		
		CFM	BHP	CFM	BHP	CFM	BHP	CFM	BHP	CFM	BHP	CFM	BHP	CFM	BHP	*Hg	CFM	BHP
404J	1750	149	3.6	139	5.3	130	7.0	123	8.7	116	10.4					14.0	115	5.9
	2950	281	7.0	271	9.8	262	12.6	255	15.4	248	18.2	239	22.4			15.0	240	11.2
	4000	396	8.3	386	14.2	378	17.9	370	21.6	364	25.3	355	30.9	347	37.0	16.0	353	15.9
406J	1750	225	5.4	210	8.0	198	10.5	187	13.0	177	15.6					14.0	173	9.0
	2950	426	10.5	411	14.7	398	18.9	387	23.1	377	27.3	363	33.6			15.0	365	16.9
	4000	601	15.0	586	20.1	574	26.0	562	31.9	552	37.0	539	46.5	526	54.0	16.0	531	23.6
409J	1750	338	8.5	315	12.0	296	15.8	279	20.0	264	23.5					14.0	259	13.5
	2950	638	15.2	615	21.5	596	27.8	579	34.1	564	40.4	544	49.8			15.0	546	24.8
	4000	900	24.0	878	30.0	859	38.1	842	46.8	827	55.0	806	67.9	788	79.0	16.0	795	35.1
412J	1750	450	11.0	420	16.0	394	21.0	372	26.0	352	32.0					14.0	343	17.7
	2950	849	19.9	819	28.3	794	36.6	772	45.0	752	53.4	724	66.0			15.0	728	32.7
	4000	1199	28.8	1169	39.9	1144	51.0	1121	62.2	1101	73.3	1074	90.0			16.0	1059	46.5
418J	1750	675	16.5	630	24.0	592	31.7	559	39.0							14.0	515	26.8
	2950	1275	29.5	1230	42.1	1192	54.7	1159	67.3							15.0	1092	48.9
	4000	1800	42.9	1755	59.7	1717	73.4	1684	93.1							16.0	1590	69.7
616J	1170	718	16.9	672	24.9	633	32.9	599	40.9	568	49.0					13.0	579	25.9
	1750	1176	26.2	1130	38.2	1091	50.1	1056	62.0	1025	73.9					14.0	1013	42.0
	3000	2162	48.9	2116	68.7	2077	88.5	2043	108.3	2012	128.0	1970				16.0	1946	81.7
624J	1170	1077	25.4	1008	37.5	950	49.5	899	61.5							13.0	869	39.0
	1750	1764	39.9	1695	57.8	1637	75.7	1585	93.6							14.0	1519	63.4
	3000	3244	77.6	3175	107.3	3117	137.0	3065	166.7							16.0	2920	124.6

RAM-J Water Sealed Performance Tables

Frame Size	Speed RPM	10" HgV		15" HgV		16" HgV		20" HgV		22" HgV		24" HgV	
		CFM	BHP	CFM	BHP	CFM	BHP	CFM	BHP	CFM	BHP	CFM	BHP
406J	1530	181	6.4	160	9.0	154	9.6	118	11.7	87	12.7	33	13.8
	2325	301	10.9	276	14.8	269	15.6	228	18.8	191	20.4	127	21.9
	3200	436	17.1	408	22.5	400	23.5	353	27.8	311	29.9	240	32.0
409J	1530	284	9.2	257	13.2	249	13.9	201	17.1	160	18.6	88	20.3
	2325	458	14.8	423	20.9	413	22.1	353	26.8	300	29.5	311	31.6
	3200	653	22.4	611	31.1	600	32.7	528	39.0	466	42.4	359	45.4
412J	1530	379	11.9	342	17.2	331	18.2	268	22.4	213	24.5	118	26.6
	2325	610	19.3	563	27.2	550	28.8	470	35.1	400	38.3	280	41.4
	3200	870	29.0	815	39.6	800	41.7	705	50.2	620	54.4	475	58.7
418J	1530	570	17.4	513	25.3	500	26.9						
	2325	815	27.7	845	39.4	825	41.9						
	3200	1305	40.9	1230	56.8	1200	59.9						
616J	1160	796	20.7	746	30.2	734	32.0	661	39.6	596	43.4	504	47.1
	1750	1245	32.7	1175	46.7	1160	49.6	1075	60.9	975	66.4	855	72.1
	2400	1703	48.3	1634	67.1	1623	70.9	1523	85.9	1434	93.5	1238	101.1
624J	1160	1192	30.1	1117	44.2	1100	47.1						
	1750	1840	46.7	1755	67.7	1725	71.9						
	2400	2552	67.1	2448	95.2	2431	100.9						

Notes:

1. Pressure ratings based on inlet air at standard pressure of 14.7 psia, standard temperature of 68° F, and specific gravity of 1.0.
2. Vacuum ratings based on inlet air at standard temperature of 68° F, discharge of 30" Hg and Specific gravity of 1.0.

RCS series

rotary positive blowers/exhausters

RCS series description



RCS rotary positive blowers are heavy-duty units designed with integral-shaft ductile iron impellers with involute profile. The headplates, gear cover, drive end cover and rigid, one-piece casing are grey iron. Carburized and ground alloy steel spur timing gears are taper mounted on the shafts, secured with a locknut. Cylindrical roller bearings are used.

Piston rings reduce air leakage through the headplate shaft openings, while lip-type oil seals prevent lubricant from entering the air chamber. All RCS series blowers are equipped with splash oil lubrication at both ends of the blower.

Unless otherwise noted, RCS series units incorporate detachable rugged steel mounting feet to permit in-field adaptability to either vertical or horizontal installation.

RCS blowers are available in frames 817 thru 827, and with ROOTS WHISPAIR frames available in 715J thru 832J.

RCS WHISPAIR rotary positive blowers

Frames 715J thru 832J



RCS WHISPAIR units reduce noise and power loss by utilizing an exclusive wrap-around plenum and proprietary WHISPAIR jet portals to control pressure equalization. The WHISPAIR jets meter discharge pressure in the direction of impeller movement, thereby aiding rotation. Discharge pulsation is reduced by the pre-pressurization of the blower chamber. Reduce pulsation results in lower noise, and reduced shock loading on the impellers.

RCS WHISPAIR units frames 817J thru 832J have feet integral to the headplates.

RCS series Performance Table

Frame Size	Speed RPM	4 PSI		6 PSI		8 PSI		10 PSI		12 PSI		15 PSI		MAX. VACUUM		
		CFM	BHP	CFM	BHP	CFM	BHP	CFM	BHP	CFM	BHP	CFM	BHP	*Hg	CFM	BHP
817	880	982	24.9	895	36.8	821	48.7	756	60.6			2003	187.7	12.0	761	35.7
	1770	2368	55.5	2281	79.5	2207	103.5	2142	127.6	2083	151.6	2751	246.8	16.0	1959	101.4
	2250	3116	78.7	3028	109.2	2955	139.8	2890	170.4	2831	200.9			16.0	2707	137.1
824	880	1326	33.1	1207	49.2	1108	65.4	1020	81.5					12.0	1028	48.2
	1770	3198	74.8	3080	107.2	2980	139.7	2892	172.2	2813	204.7	2705	253.4	16.0	2646	136.8
	2250	4208	105.6	4090	147.2	3990	188.5	3902	229.8	3823	271.1	3715	333.0	16.0	3656	184.9
827	880	1519	37.9	1383	56.4	1269	74.9	1169	93.4					12.0	1178	55.2
	1770	3665	85.5	3529	122.7	3415	159.9	3314	197.1	3223	234.3			16.0	3032	157.0
	2250	4822	120.9	4687	168.2	4572	215.5	4472	262.8	4381	310.1			16.0	4189	212.3

RCS-J series Performance Table

Frame Size	Speed RPM	4 PSI		6 PSI		8 PSI		10 PSI		12 PSI		15 PSI		18 PSI		MAX. VACUUM		
		CFM	BHP	CFM	BHP	CFM	BHP	CFM	BHP	CFM	BHP	CFM	BHP	CFM	BHP	*Hg	CFM	BHP
715J	1180	935	23.0	870	33.4	815	44.0	766	54.6	722	65.0	663	81.0			14.0	705	37.2
	1770	1548	37.3	1483	53.0	1428	68.8	1379	84.5	1335	100.3	1276	12.9			15.0	1281	61.4
	2600	2410	63.4	2345	86.0	2290	108.5	2241	131.0	2198	153.7	2138	187.5			15.0	2144	95.4
721J	1180	1266	30.5	1178	44.8	1103	59.0	1037	73.5	978	87.8	892	109.2			14.0	955	50.0
	1770	2096	49.1	2008	70.4	1933	91.7	1867	113.1	1808	134.4	1727	166.4			15.0	1735	81.7
	2600	3264	81.4	3176	112.0	3101	142.5	3035	173.1	2976	203.7	2895	249.5			15.0	2903	124.8
817J	880	982	24.9	895	36.8	821	48.7	756	60.6							16.0	1962	95.9
	1770	2368	55.0	2280	78.5	2206	102.0	2142	125.4	2083	148.9	2004	184.1	2055	219.4	16.0	1962	95.9
	2250	3116	75.6	3028	105.0	2955	134.0	2890	164.0	2830	193.0	2751	237.0	2680	281.0	16.0	2707	126.0
821J	880	1179	29.6	1074	43.9	985	58.1	907	72.4							16.0	2354	114.8
	1770	2842	65.7	2738	93.9	2648	122.1	2571	150.3	2500	178.4	2405	220.7			16.0	2354	114.8
	2250	3740	92.3	3635	127.0	3546	163.0	3468	198.0	3398	233.0	3302	286.0			16.0	3249	153.0
826J	880	1473	37.1	1342	55.0	1231	72.8	1134	90.7							16.0	2944	142.8
	1770	3554	81.4	3423	116.7	3311	151.9	3214	187.1	3126	222.3					16.0	2944	142.8
	2250	4676	105.0	4545	156.0	4434	200.0	4336	247.0	4248	288.0					16.0	4062	188.0
832J	880	1768	44.4	1610	65.8	1477	87.2	1360	108.6							16.0	3531	168.4
	1770	4264	97.5	4107	139.8	3972	182.0	3857	224.3							16.0	3531	168.4
	2250	5610	134.0	5452	186.0	5320	239.0	5202	292.0							16.0	4874	225.0

Notes:

1. Pressure ratings based on inlet air at standard pressure of 14.7 psia, standard temperature of 68° F, and specific gravity of 1.0.
2. Vacuum ratings based on inlet air at standard temperature of 68° F, discharge of 30" Hg and Specific gravity of 1.0.
3. 800J frame sizes only - Operation above 15 psi pressure rise, 15" Hg vacuum or 230° F temperature rise requires oil coolers - refer to factory. Oil coolers not available on 600J and 700J frame sizes.

WHISPAIR DRY EXHAUSTERS

Basic Dry Exhausters Description

ROOTS™ dry exhausters feature an exclusive discharge jet plenum designed to allow cool, atmospheric air to flow into the casing. This unique design permits continuous operation at levels to blank-off with a single stage unit, without water injection or heat exchangers.

Competitor's dry exhausters, not having the benefit of the WHISPAIR™ jet plenum are limited to approximately 16" Hg due to extreme discharge temperatures resulting in casing and impeller distortion.

Headplates and the rigid casing are cast from grey iron, with aluminum drive end and gear covers. Carburized ground alloy steel spur timing gears are securely mounted on taper end shafts.

All DVJ exhausters are designed with detachable steel mounting feet to permit in-field adaptability to discharge left, right or vertically upwards.

WHISPAIR dry exhausters



Frame 2504 DVJ

Frame 2504 DVJ units feature ball bearings, with splash lubrication at the gear end and grease lubrication at the drive end. Lip-type seals restrict oil leakage into the air stream.

Frame 721 DVJ

Frame 721 DVJ units feature cylindrical roller bearings with splash lubrication at both the gear end and the drive end. Lip-type seals restrict oil leakage into the air stream.

RAM WHISPAIR dry exhausters

Frame 406 DVJ, 412 DVJ, and 616 DVJ



RAM DVJ units feature integral-shaft ductile iron impellers with involute profiles. Headplates and the rigid casing are cast grey iron, while gearbox and end covers are aluminum. Carburized ground alloy steel spur timing gears are securely mounted on taper end shafts. The top shaft is extended for drive side outlet blowers, and either shaft can be extended for drive on top or bottom outlet blowers. RAM DVJ units feature cylindrical roller bearings for maximum life.

Piston ring shaft seals reduce gas leakage through the headplates, while lip-type oil seals prevent lubricant from entering the air chamber. RAM DVJ units are splash lubricated on both sides with high volume oil reservoirs.

RAM DVJ units can be equipped with mechanical seals for gas applications. Please contact the factory for more information.

RAM WHISPAIR DRY HIGH PRESSURE BLOWERS

Frame 406 DPJ



ROOTS™ dry high-pressure blowers feature an exclusive discharge jet plenum designed to allow externally cooled gas to flow into the casing. Additionally, the ROOTS WHISPAIR jets control pressure equalization by feeding backflow in the direction of impeller movement, thereby aiding rotation.

The unique WHISPAIR design permits continuous operation with discharge pressures up to 30 PSIG in a single stage unit. ROOTS high-pressure units produce temperatures up to 370°F, and are therefore ideal for designing systems with plant heat co-generation capabilities.

Headplates and the rigid casing are forged from grey iron, with aluminum drive end and gear covers. Carburized ground alloy steel spur timing gears are securely mounted on taper end shafts. RAM DPJ units

feature integral-shaft ductile iron impellers with involute profiles. RAM DPJ units feature cylindrical roller bearings and is splash lubricated at both the gear and drive ends. Piston rings are used to reduce air leakage through the headplate shaft openings, while lip-type oil seals prevent lubricant from entering the air chamber.

All DPJ high-pressure blowers are designed with detachable steel mounting feet to permit in-field adaptability to either left, right or vertically upwards.

The top shaft is extended for drive side outlet blowers, and either shaft can be extended for drive on top outlet blowers.

RAM DPJ units are suitable for air or gas applications.

Performance Table

Dry Vacuum Exhausters & Dry High Pressure Blowers

DVJ

Frame Size	Speed RPM	MAXIMUM FREE AIR CFM	12" HgV		16" HgV		20" HgV		24" HgV		27" HgV	
			CFM	BHP	CFM	BHP	CFM	BHP	CFM	BHP	CFM	BHP
406J	2320	668	266	10.3	229	13.5	178	16.7	80	20.0	*	23.0
	2695		329	12.2	292	15.8	241	19.5	143	23.2	*	27.0
	3564		474	16.9	437	21.4	386	26.2	288	30.9	47	34.5
	4000		547	19.5	510	24.4	459	29.6	361	34.8	120	38.8
412J	2320	1332	531	20.2	457	26.6	355	33.1	160	39.6	*	45.0
	2695		656	23.7	581	31.1	480	38.6	285	46.1	*	52.0
	3564		945	32.2	871	41.7	769	51.4	574	61.2	94	68.5
	4000		1091	36.3	1016	47.1	914	58.0	719	68.9	239	77.0
616J	1750	2367	1015	36.0	903	48.0	750	59.0	445	71.0	*	80.0
	2124		1311	44.0	1198	58.0	1045	72.0	750	86.0	*	97.0
	2437		1558	51.0	1445	67.0	1292	83.0	997	99.0	271	111.0
	2860		1890	60.0	1777	79.0	1623	98.0	1324	117.0	578	131.0
	3000		2002	63.0	1889	85.0	1736	103.0	1441	123.0	715	136.7

DPJ

Frame Size	Speed RPM	15 PSI		20 PSI		25 PSI		30 PSI	
		CFM	BHP	CFM	BHP	CFM	BHP	CFM	BHP
406 DPJ	4000	545	46	525	60	510	75	495	88
	3070	390	35	370	46	355	57	340	68
	2320	265	26	245	35	230	43	215	52
	1750	170	20	150	26	134	32	118	39

Notes:

1. Vacuum ratings based on inlet and jet air at standard pressure standard temperature of 68° F, discharge and jet pressure of 30" Hg and specific gravity of 1.0.
2. Refer to Factory for performance guarantee above 24" HgV.
3. DPJ ratings based on inlet air at standard pressure of 14.7 psia, standard temperature of 68° F, and specific gravity of 1.0.

Configurations

ROOTS Blowers & Compressors are available in two basic configurations to meet nearly any piping arrangement or installation requirement. Determine orientation for inlet and discharge connections from the drive end:

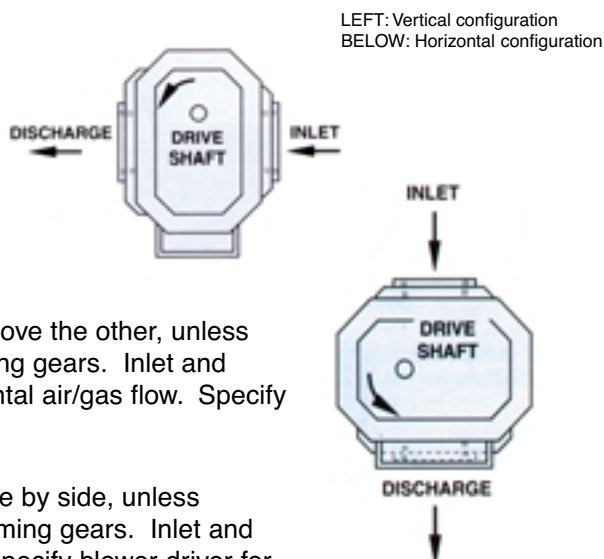

Vertical Configuration:

For vertical configurations, one impeller is mounted above the other, unless otherwise noted the blower drive end located opposite the timing gears. Inlet and discharge connection flanges are positioned to provide horizontal air/gas flow. Specify blower driver for either top or bottom connection.

Horizontal Configuration:

For horizontal configurations, impellers are located side by side, unless otherwise noted the blower drive end is located opposite the timing gears. Inlet and discharge connection flanges provide a vertical air/gas flow. Specify blower driver for either left or right hand blower shaft.

Special Note: URAI-J™ models are designed to operate with only one shaft rotation direction to take full advantage of the Whispair feature. Therefore, a URAI-J™ blower should be operated in the following combinations only.

- CCW Rotation: Bottom Shaft; Right side discharge or a Left Shaft; Bottom discharge.
- CCW Rotation: Top Shaft; Left side discharge or a Right Shaft; Top discharge.
- CW Rotation: Bottom Shaft, Left side discharge or a Right Shaft; Bottom discharge.
- CW Rotation: Top Shaft, Right side discharge or a Left Shaft; Top discharge.

Dimensional Drawings & Tables

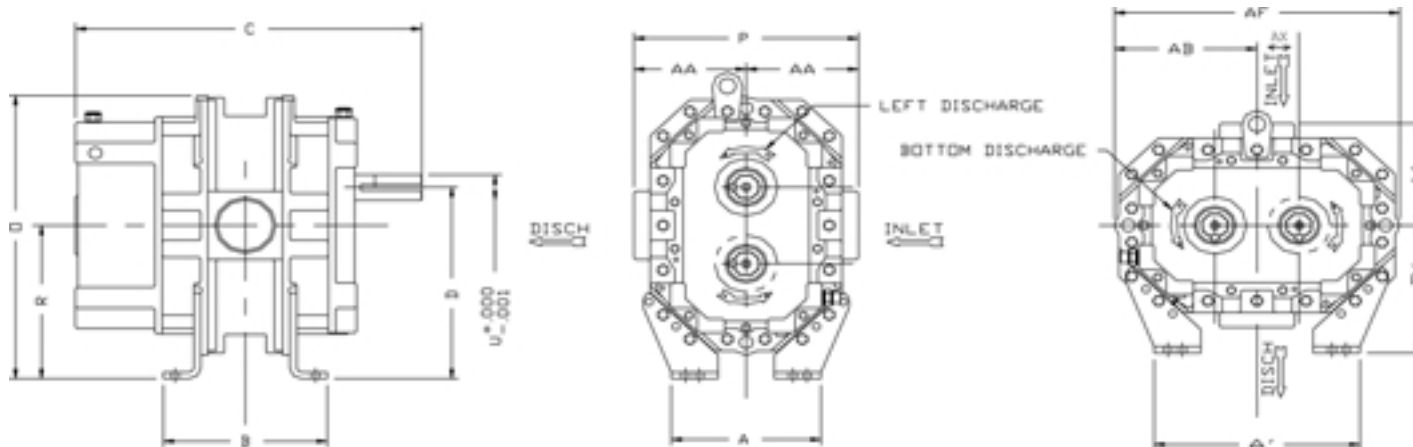

RCS Dimensional Table

Frame Size	A	A'	B	C	Drive Shaft Location		O	O'	P	P'	R	U	Keyway	AF Inlet Diameter	AX	Approx. Net Wt. (lbs)
					D	D1										
817	19.00	27.00	24.25	38.44	18.00	10.00	28.38	20.38	19.00	25.25	14.00	2.750	.625 x .313	10.0 FLG	4.00	1200
824	19.00	27.00	30.50	44.69	18.00	10.00	28.38	20.38	19.00	25.25	14.00	2.750	.625 x .313	12.0 FLG	4.00	1330
827	19.00	27.00	34.00	48.19	18.00	10.00	28.38	20.38	19.00	25.25	14.00	2.750	.625 x .313	14.0 FLG	4.00	1600

URAI Dimensional Table

Frame Size	A	B	C	Drive Shaft Location			O	O'	P	P'	R	U	Keyway	Inlet & disch. Dia.	AX	Approx. Net Wt. (lbs.)
				D	D1	D2										
22	5.13	5.00	9.75	3.75	6.25	3.75	9.63	6.88	6.25	9.25	5.00	.625	.188 x .094	1.0 NPT	1.25	32
24	5.13	7.00	11.75	3.75	6.25	3.75	9.63	6.88	6.25	9.25	5.00	.625	.188 x .094	2.0 NPT	1.25	43
32	7.25	6.75	11.25	5.00	8.50	5.00	12.81	8.88	7.75	12.13	6.75	.750	.188 x .094	1.25 NPT	1.75	69
33	7.25	7.63	12.13	5.00	8.50	5.00	12.81	8.88	7.75	12.13	6.75	.750	.188 x .094	2.0 NPT	1.75	74
36	7.25	10.00	14.63	5.00	8.50	5.00	12.81	8.88	7.75	12.13	6.75	.750	.188 x .094	2.5 NPT	1.75	102
42	8.00	7.25	13.00	6.25	10.25	6.25	15.06	10.63	8.75	13.63	8.25	.875	.188 x .094	1.5 NPT	2.00	88
45	8.00	10.00	15.50	6.25	10.25	6.25	15.06	10.63	8.75	13.63	8.25	.875	.188 x .094	2.5 NPT	2.00	109
47	8.00	11.75	17.63	6.25	10.25	6.25	15.06	10.50	8.50	13.63	8.25	.875	.188 x .094	3.0 NPT	2.00	128
53	10.50	8.38	15.38	6.25	11.25	6.75	17.38	11.88	10.25	17.25	8.75	1.125	.250 x .125	2.5 NPT	2.50	143
56	10.50	11.00	18.00	6.25	11.25	6.75	17.38	12.25	11.00	17.25	8.75	1.125	.250 x .125	4.0 NPT	2.50	170
59	10.50	14.00	21.18	6.25	11.25	6.75	17.38	12.25	11.00	17.25	8.75	1.125	.250 x .125	4.0 NPT	2.50	204
65	11.00*	10.00	18.38	8.75	14.75	8.75	21.63	15.13	12.75	19.75	11.75	1.375	.312 x .156	3.0 NPT	3.00	245
68	11.00*	13.00	21.38	8.75	14.75	8.75	21.63	15.13	12.75	19.75	11.75	1.375	.312 x .156	5.0 NPT	3.00	285
615	11.00*	20.00	28.38	8.75	14.75	8.75	21.63	16.25	15.00	19.75	11.75	1.375	.312 x .156	6.0 FLG	3.00	425
76	14.00**	11.75	19.94	11.00	18.00	11.00	26.13	20.69	19.38	23.25	14.50	1.562	.375 x .188	4.0 NPT	3.50	400
711	14.00**	16.75	25.19	11.00	18.00	11.00	26.13	19.50	17.00	23.25	14.50	1.562	.375 x .188	6.0 FLG	3.50	530
718	14.00**	23.75	32.19	11.00	18.00	11.00	26.13	19.50	17.00	23.25	14.50	1.562	.375 x .188	8.0 FLG	3.50	650

RAM Dimensional Table

Frame Size	A	A'	B	C	Drive Shaft Location		O	O'	P	P'	R	U	Keyway	AF Inlet Diameter	AX	Approx. Net Wt. (lbs)
					D	D1										
404	8.00	11.00	8.75	18.50	11.25	7.50	16.63	13.50	12.00	15.25	9.00	1.500	.375 x .188	3.0 NPT	2.25	200
406	8.00	11.00	10.75	20.50	11.25	7.50	16.63	13.50	12.00	15.25	9.00	1.500	.375 x .188	4.0 NPT	2.25	230
409	8.00	11.00	13.75	23.50	11.25	7.50	16.63	13.00	11.00	15.25	9.00	1.500	.375 x .188	4.0 NPT	2.25	270
412	8.00	11.00	16.75	26.50	11.25	7.50	16.63	13.00	11.00	15.25	9.00	1.500	.375 x .188	6.0 FLG	2.25	330
418	8.00	11.00	22.75	32.50	11.25	7.50	16.63	13.00	11.00	15.25	9.00	1.500	.375 x .188	8.0 FLG	2.25	410
616	10.00	16.00	20.75	32.44	15.00	9.00	22.00	16.25	14.50	20.00	12.00	2.000	.500 x .250	8.0 FLG	3.00	650
624	10.00	16.00	28.75	40.44	15.00	9.00	22.00	16.25	14.50	20.00	12.00	2.000	.500 x .250	10.0 FLG	3.00	775

Dimensional Drawings & Tables cont.

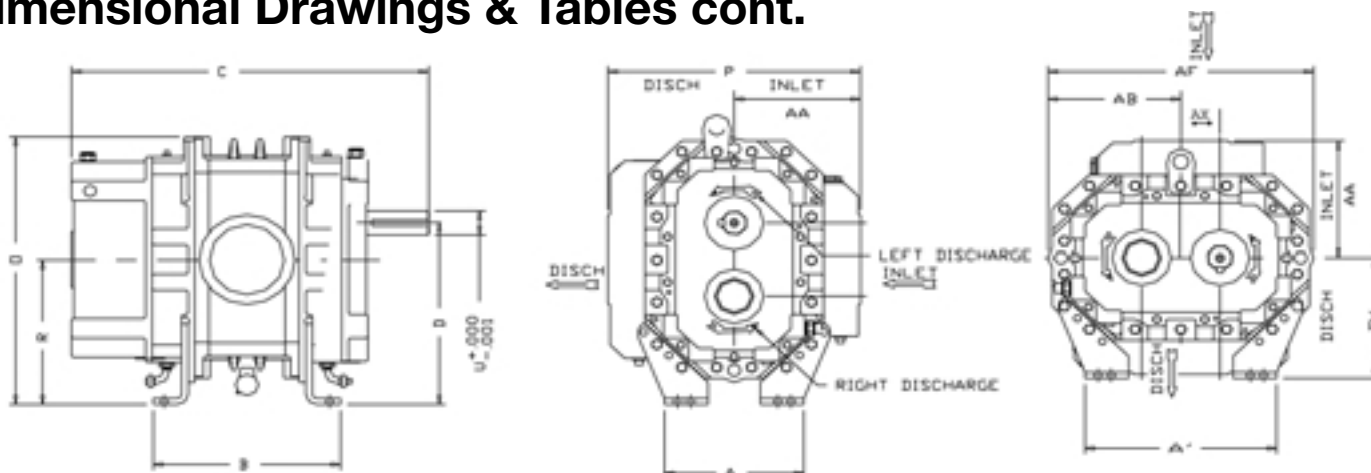

URAI-J Dimensional Table

Frame Size	A	B	C	Drive Shaft Location			O	O'	P	P'	R	U	Keyway	Inlet & disch. Dia.	AX	Approx. Net Wt. (lbs.)
				D	D1	D2										
33J	7.25	7.63	12.13	5.00	8.50	5.00	12.81	10.00	10.00	12.13	6.75	.750	.188 x .094	2.0 NPT	1.75	84
36J	7.25	10.00	14.63	5.00	8.50	5.00	12.81	10.50	11.00	12.13	6.75	.750	.188 x .094	2.5 NPT	1.75	112
45J	8.00	10.00	15.50	6.25	10.25	6.25	15.06	12.25	12.00	13.63	8.25	.875	.188 x .094	2.5 NPT	2.00	119
47J	8.00	11.75	17.63	6.25	10.25	6.25	15.06	12.25	12.00	13.63	8.25	.875	.188 x .094	3.0 NPT	2.00	138
56J	10.50	11.00	18.00	6.25	11.25	6.75	17.38	14.00	14.50	17.25	8.75	1.125	.250 x .125	4.0 NPT	2.50	180

RAM-J Dimensional Table

Frame Size	A	A'	B	C	Drive Shaft Location		O	O'	P	P'	R	U	Keyway	AF Inlet Diameter	AF' Diameter	AA	AX	Approx. Net Wt. (lbs)
					D	D1												
404J	8.00	11.00	8.75	18.50	11.25	7.50	16.63	14.75	14.50	15.25	9.00	1.500	.375 x .188	3.0 NPT	3.0 NPT	7.25	2.25	270
406J	8.00	11.00	10.75	20.50	11.25	7.50	16.63	14.75	14.50	15.25	9.00	1.500	.375 x .188	4.0 NPT	4.0 NPT	7.25	2.25	300
409J	8.00	11.00	13.75	23.50	11.25	7.50	16.63	14.75	14.50	15.25	9.00	1.500	.375 x .188	5.0 NPT	5.0 NPT	7.25	2.25	350
412J	8.00	11.00	16.75	26.50	11.25	7.50	16.63	13.50	13.00	15.25	9.00	1.500	.375 x .188	6.0 FLG	5.0 FLG	6.00	2.25	400
418J	8.00	11.00	22.75	32.50	11.25	7.50	16.63	14.50	14.00	15.25	9.00	1.500	.375 x .188	8.0 FLG	6.0 FLG	7.00	2.25	500
616J	9.00	15.00	20.75	32.19	15.00	9.00	22.00	16.50	16.25	20.00	12.00	2.000	.500 x .250	8.0 FLG	6.0 FLG	7.50	3.00	700
624J	9.00	15.00	28.75	40.19	15.00	9.00	22.00	17.75	17.50	20.00	12.00	2.000	.500 x .250	10.0 FLG	8.0 FLG	8.75	3.00	910

XLP Dimensional Table

Frame Size	A	A'	B	C	D	D'	O	O'	P	R	U	KEYWAY	INLET & DISCH. DIA.	AA	AA'	AX	APPROX. NET WT. (LBS.)
110	12.95	19.76	18.11	28.82	7.44	6.50	16.02	12.20	12.40	9.88	45.03 / 45.011	5.5 / 5.7	150	5.71	6.69	2.44	169
108	12.95	19.76	23.23	33.74	7.44	6.50	16.02	12.20	12.40	9.88	45.03 / 45.011	5.5 / 5.7	150	5.71	6.69	2.44	202
210	17.24	25.98	24.80	37.32	9.84	8.66	24.21	15.94	15.63	12.99	60.03 / 60.011	7.0 / 7 / 2	200	7.28	8.35	3.15	340
208	17.24	25.98	31.10	43.62	9.84	8.66	24.21	15.94	15.63	12.99	60.03 / 60.011	7.0 / 7 / 2	250	7.28	8.35	3.15	375

RCS-J Dimensional Table

Frame Size	A	A'	B	C	Drive Shaft Location		O	O'	P	P'	R	U	Keyway	AF Inlet Diameter	AF' Diameter	AA	AX	Approx. Net Wt. (lbs)
					D	D1												
715J	19.00	26.00	21.50	33.88	17.00	10.00	25.13	19.00	18.00	23.25	13.50	2.375	.625 x .313	10.0 FLG	8.0 FLG	9.00	3.50	1100
721J	19.00	26.00	27.00	39.38	17.00	10.00	25.13	19.00	18.00	23.25	13.50	2.357	.625 x .313	12.0 FLG	10.0 FLG	9.00	3.50	1200
817J	13.75	22.00	24.25	38.63	21.00	13.00	30.00	25.75	25.50	25.00	17.00	2.750	.625 x .313	10.0 FLG	10.0 FLG	12.75	4.00	1620
821J	13.75	22.00	27.88	42.25	21.00	13.00	30.00	25.75	25.50	25.00	17.00	2.750	.625 x .313	12.0 FLG	10.0 FLG	12.75	4.00	1800
826J	13.75	22.00	33.13	47.50	21.00	13.00	30.00	25.75	25.50	25.00	17.00	2.750	.625 x .313	12.0 FLG	12.0 FLG	12.75	4.00	2075
832J	13.75	22.00	38.50	52.88	21.00	13.00	30.00	25.75	25.50	25.00	17.00	2.750	.625 x .313	14.0 FLG	12.0 FLG	12.75	4.00	2325

Dimensional Drawings & Tables cont.

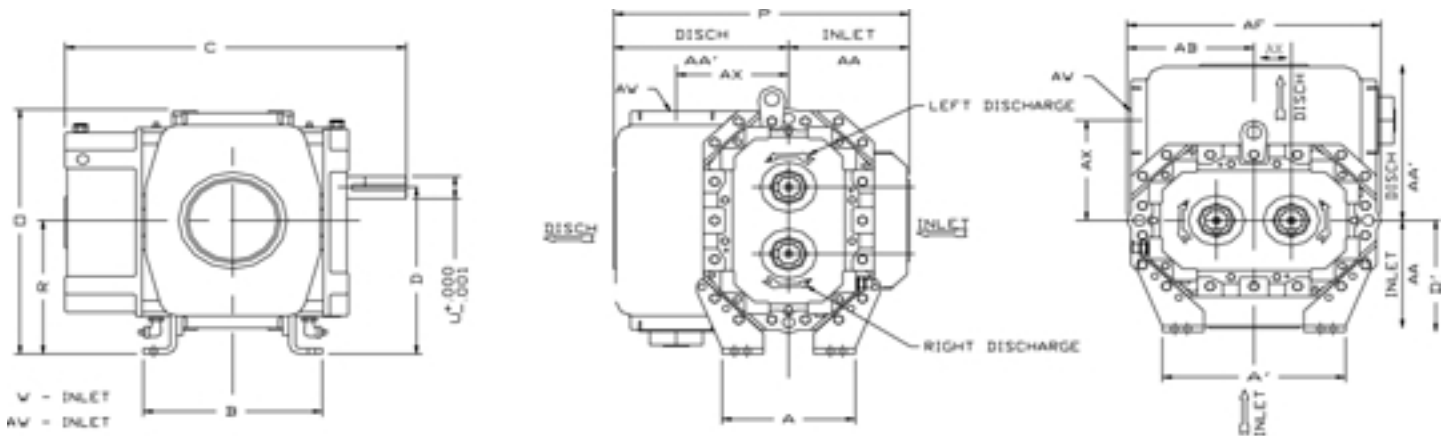

DVJ Dimensional Table

Frame Size	A	A'	B	C	D	D'	O	O'	P	P'	R	R'	U	KEYWAY	AA	AA'	AB	AF	AF'	AW	AX	APPROX. NET WT. (LBS.)
406J	8.00	11.00	10.75	20.50	11.25	7.50	16.38	18.00	17.75	14.75	9.00	7.38	1.500	.375 x .188	7.25	10.50	6.75	4 NPT	5 NPT	4 NPT	2.25	365
412J	8.00	11.00	16.75	26.50	11.25	7.50	16.63	19.25	17.75	15.25	9.00	7.63	1.500	.375 x .188	6.00	11.75	6.50	6 FLG	6 FLG	5 FLG	2.25	575
616J	10.00	16.00	21.44	32.50	15.00	9.00	21.63	22.75	21.25	19.25	12.00	9.63	2.000	.500 x .250	7.50	13.75	6.75	8 FLG	10 FLG	8 FLG	3.00	975

DPJ Dimensional Table

Frame Size	A	A1	B	C	Drive Shaft Location		O	O'	P	P'	R	R'	U	KEYWAY	AA	AA'	AB	AF	AF'	AW	AX	WGT (LBS.)
					D	D1																
406 DPJ	8.00	11.00	10.75	20.50	11.25	7.50	16.38	18.00	17.75	14.75	9.00	7.38	1.500	.375 X .188	7.25	10.50	6.75	4 NPT	5 NPT	4 NPT	2.25	365

Typical Application Packages

Pressure Application



Gas Application

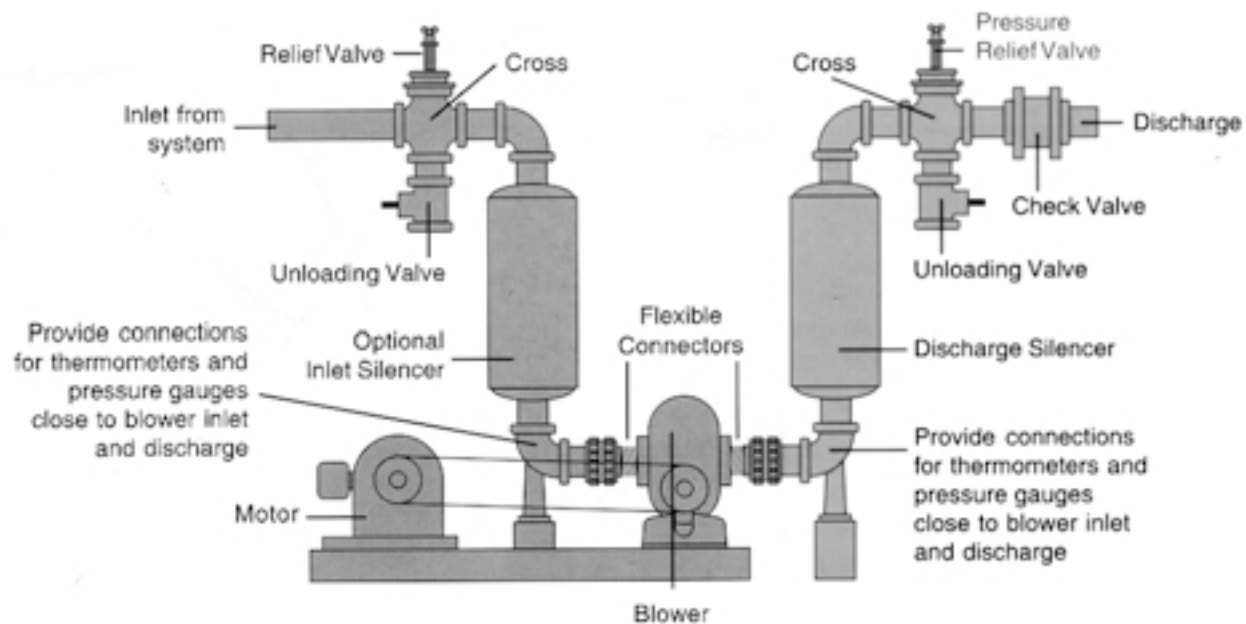

Exhauster Application

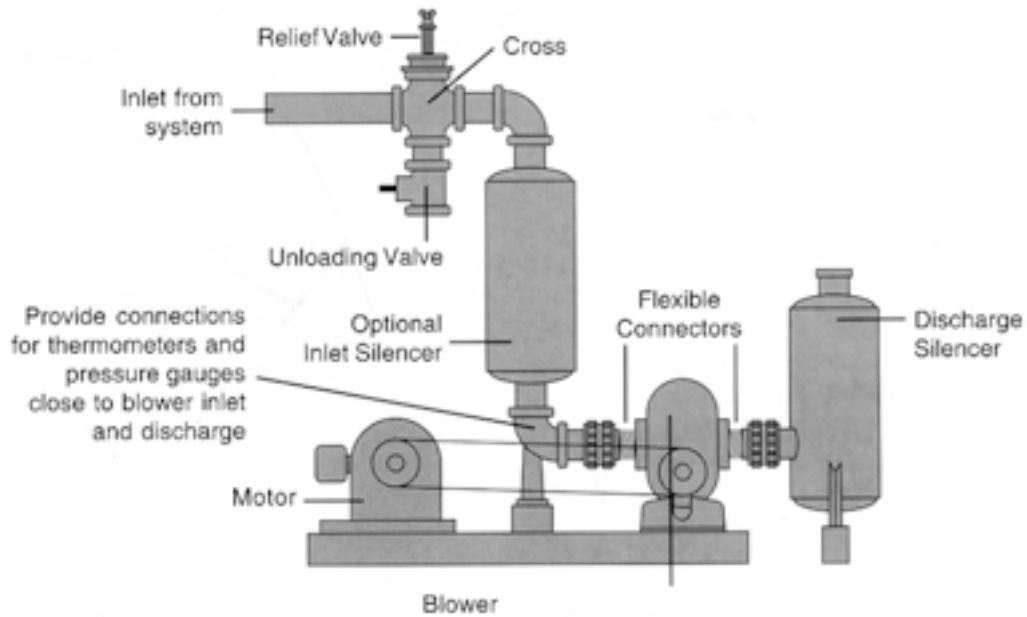

High Vacuum Application

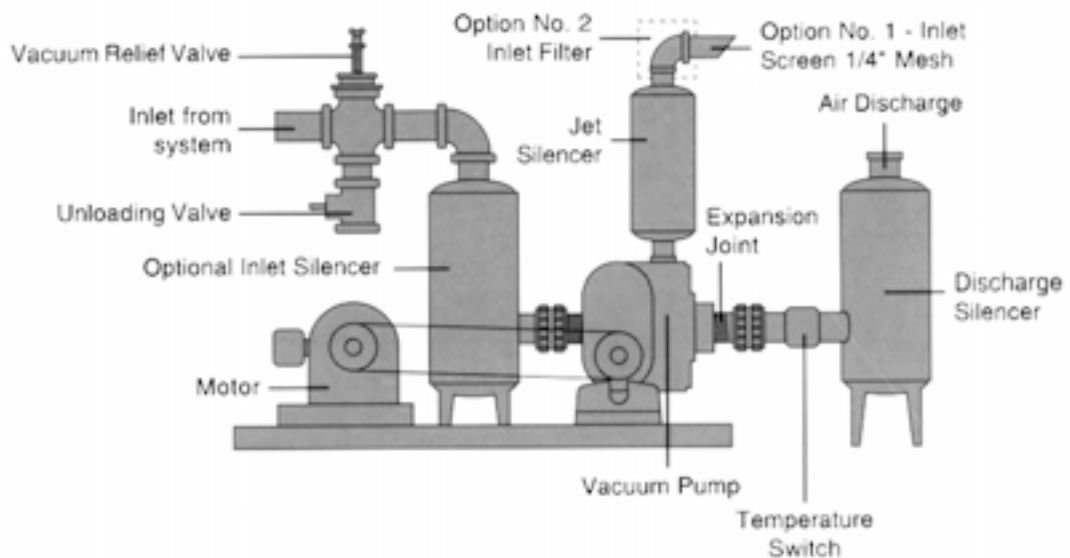

Other ROOTS products



Authorized ROOTS Distributor

- Authorization requires every ROOTS Distributor's service department to have a minimum of 16 hours factory training with ROOTS.
- BI-annual factory refresher courses for new products and techniques keep each Authorized Distributor's service department proficient, reducing repair time and costs.
- ROOTS Authorized Distributors have special factory-designed tools to fulfill your service needs quickly and effectively.
- Authorization requires Distributors to maintain facilities for repairs testing. Authorized Distributor repair work is proved before it ships.
- You get complete ROOTS warranty service/replacement directly from your Factory Authorized Distributor.

Dresser, Inc.



Roots

Global Technology & Engineering
PO Box 687
Excelsior Springs, MO 64024
PH:816-630-3500
FX:816-630-3504
Toll Free: 1-866-630-3500

B-50X93
April 2002

20

Copyright 2002 Dresser, Inc. All rights reserved.
ROOTS, RAM and XLP WHISPAIR are Trademarks of Dresser, Inc.
Universal RAI, U-RAI and are registered Trademarks of Dresser, Inc.

website: www.globaltecheng.com • email: sales@globaltecheng.com